

MECH-TECH SYSTEMS CCU MODEL FOR 1911 PISTOLS

Operation & Maintenance Manual



Read and understand this manual before attempting to use this product. If you have any questions call:

1-866-433-2122

www.mechtechsys.com

Made in the USA

Copyright Mech-Tech Systems, Inc.
2014 All rights reserved

MECH-TECH 1911 CCU OPERATION AND MAINTENANCE MANUAL

SAFETY INSTRUCTIONS AND WARNINGS

Read and understand this entire manual before attempting operation or maintenance of the CCU (Carbine Conversion Unit). Always point the muzzle in a safe direction. Assume all firearms are loaded. Take extra precautions to secure them from children. Observe all safety precautions. Wear approved ear and eye protection when firing the CCU. Obey local, state and Federal laws at all times.

Do not modify any CCU components. Doing so will void the warranty.

At all times during assembly, disassembly, and/or maintenance of the CCU make certain that the CCU and pistol frame are clear of any ammunition. The magazine must be removed from the pistol before assembly.

The CCU bolt is a spring loaded assembly. When the bolt handle is in the locked position it is possible under certain conditions for the bolt to slam shut (bolt handle bumped, jarred, etc.) Keep fingers clear of the ejection port to avoid injury.

Be certain to read and understand all assembly and disassembly instructions before using your CCU. Always wear appropriate eye protection during these procedures.

When the CCU is installed on the frame of the pistol for which it was designed, the complete assembly becomes a functioning firearm. This assembly operates in the same semi-automatic mode as the pistol from which the lower unit originated, however the bolt does **NOT** lock open after the last round has been fired. Observe all of the safety precautions which apply to the pistol as outlined by the pistol manufacturer.

Use only ammunition of the caliber for which the CCU is designed. Only use high quality ammunition loaded by licensed commercial ammunition manufacturers (factory ammunition) which meets applicable SAAMI, CIP or NATO standards. The use of reloads or ammunition from unknown suppliers has the potential to be unsafe and also will void the warranty of the CCU.

WARNING: NEVER USE AMMUNITION WITH PRESSURE LEVELS THAT EXCEED INDUSTRY STANDARDS. ALL WARRANTIES, EXPRESS AND IMPLIED WILL BE VOIDED. THE MECH-TECH CCU IS DESIGNED TO FIRE UP TO +P AMMUNITION. NEVER USE AMMUNITION WITH HIGHER PRESSURE LEVELS. MECH-TECH SYSTEMS INC. WILL NOT BE LIABLE FOR PROPERTY DAMAGE OR PERSONAL INJURY AND CONSEQUENTIAL DAMAGES. USE ONLY UNMODIFIED PISTOL LOWERS. MECH-TECH REQUIRES THE SAME CRITERIA FOR SAFETY THAT IS REQUIRED BY PISTOL MANUFACTURERS. AFTERMARKET PARTS AND OTHER MODIFICATIONS TO PISTOL FRAMES MAY NOT FUNCTION WHEN USED WITH THE CCU AND MAY VOID YOUR WARRANTY.

NOTE: 1911 style pistols have a frame mounted safety lever on the left side. The CCU allows this safety to operate if the lever is the same as a stock Colt original pattern. Extended style safety levers such as are available from aftermarket sources and are found on later manufactured 1911 style pistols may not function with the CCU.

1) INSTALLATION

Fig. 1 & Fig. 2 show a 1911 CCU basic unit and indicate the major components and features involved. Observe in **Fig. 2** the tab relief openings which allow for the assembly of the 1911 pistol frame onto the CCU housing.

First prepare your pistol for assembly by removing the magazine and slide assembly from your pistol. Cock the hammer. Next, pull the CCU bolt to the rear and lock it in place by pushing the bolt handle into the detente in the housing. If your CCU has the fixed stock, you will need to slide it back about a half inch to expose the hammer relief.

Hold the CCU in one hand and the pistol lower in the other, pointing in a safe direction. Match the rails on the pistol to the rail relief openings on the CCU. With the pistol evenly pressed against the underside of the CCU push the pistol forward until it stops. Now insert the pistol's

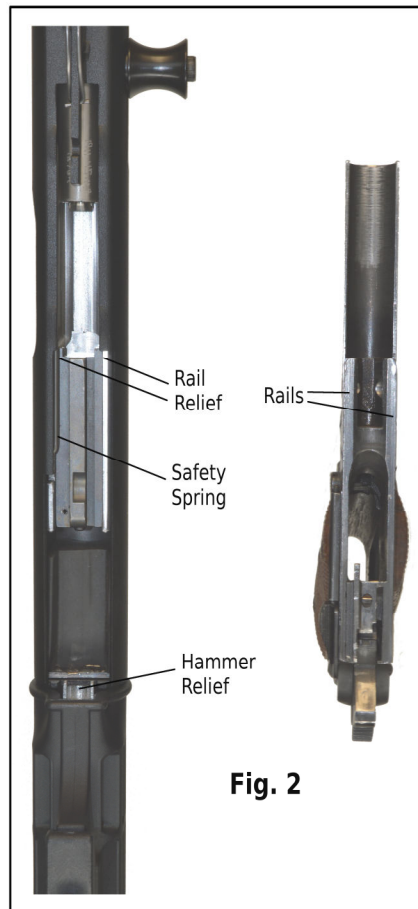
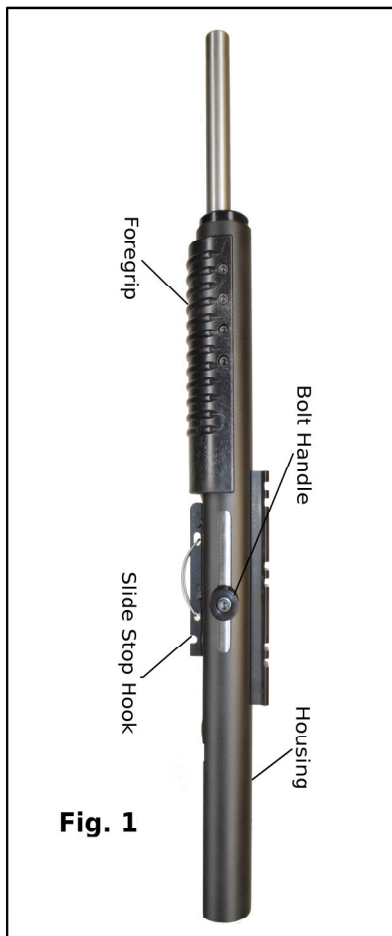

slide stop.

Once the pistol is attached to the CCU the magazine can be inserted. To chamber the first round pull the bolt handle out of the detente and release. The bolt will slam forward and chamber the cartridge. The assembled Mech-Tech CCU will function just like a semi-automatic pistol, one shot per trigger pull. Safety always comes first. It is the responsibility of the operator to be aware of the condition of the CCU at all times. **Tip:** when the bolt is closed, a portion of the cartridge case is visible through the ejection port when the chamber is loaded.

There is a safety device designed into the CCU which prevents the installation of a frame into the CCU with the bolt in the closed position. The reason for this device is to prevent an accidental discharge in the event that a live round is in the chamber at the time of assembly.

2) DISASSEMBLY

Make certain that all ammunition is removed from the CCU. Remove the magazine from the pistol frame and lock the bolt open.

Remove the slide stop pin and slide the pistol frame to the rear until it clears the housing 'rails' and remove it from the housing.

Disassembly is complete.

3) MAINTENANCE

It is not necessary to "Field Strip" the CCU after each use. Mech-Tech advises against this procedure. Under normal use the CCU can be thoroughly cleaned using the methods outlined

in this manual. If the CCU has experienced excessive use or has been exposed to water Field Stripping is required. The main concern with disassembly is the eight (8) screws in the fore-grip. They thread into an aluminum support for the barrel. Although we have not seen problems, repeated unnecessary removal/installation of the screws could result in damage to the threads. The CCU requires cleaning and lubrication on the same basis as your pistol. With the pistol removed inspect the chamber to ensure the CCU is not loaded. Lock the bolt open. It is advised to hold the bolt handle firmly against the housing when cleaning. The bolt can inadvertently slam closed causing injury. Clean the barrel bore and chamber the same as with other firearm systems.

The inside of the housing in the areas where the bolt slides can be cleaned most effectively using an aerosol type gun solvent. After it is clean, wipe dry and apply lubricant as needed. Mech-Tech does not recommend gun grease. Over lubrication usually does more harm than good, so only apply as needed.

4) FIELD STRIPPING

Before attempting disassembly be certain to read these instructions all the way through. Always wear suitable eye protection when working on or cleaning the CCU.

There are three major sub-assemblies in the CCU. These are:

- Barrel assembly
- Bolt Channel sub-assembly
- Main Housing sub-assembly

Disassembly instructions vary depending on the rail system your CCU has installed.

FOR DISASSEMBLY OF THE BASE MODEL:

1. Open bolt and check that the chamber is clear. Close bolt.
2. Remove bolt handle with a 5/32" hex wrench.
3. Remove the eight (8) screws in the fore grip with a 9/64" hex wrench.
4. Pull the barrel and slide the complete assembly out of the housing. The Safety Spring may fall out of the channel when it clears the housing. (NOTE: The barrel and bolt channel assemblies are held together with the recoil spring. Keep the two assemblies flat to prevent the spring from sliding off the retaining posts on either end. This will damage the spring and require replacement). Using Needle Nose pliers, or suitable tool, remove the spring from one of the posts. Release spring tension slowly and remove. Separate the barrel assembly from the bolt channel assembly. No further disassembly is needed.

DISASSEMBLY INSTRUCTIONS FOR CCU'S WITH THE QUAD-RAIL:

Follow steps 1-2 under BASE MODEL.

Remove the bottom rail using a 3/32" hex wrench.

Remove the Side Rails and Lower Housing Clamp.

Remove the 3/32" screw at the end of the long rail. Do not remove the Barrel Clamp.

Follow steps 3-4 under Base Model.

DISASSEMBLY INSTRUCTIONS FOR CCU'S WITH THE MONO-RAIL AND MONO-RAIL W/MINI-RAIL:

Follow steps 1-3 under BASE MODEL.

Remove the 3/32" screw at the end of the long rail. Do not remove the barrel clamp.

Follow Step 4 under BASE MODEL.

For MONO-RAIL W/ MINI-RAIL FOLLOW THE ABOVE PROCEDURE. LOOSEN ONLY the side and bottom MINI-RAILS. Follow Step 4 under BASE MODEL.

DISASSEMBLY INSTRUCTIONS FOR CCU'S WITH THE MINI QUAD-RAIL:

Follow steps 1-3 under BASE MODEL.

LOOSEN ONLY the eight (8) screws retaining the MINI-RAILS.

Follow step 4 under BASE MODEL.

REASSEMBLY INSTRUCTIONS-BASE MODEL:

1. Make sure front buffer (white disk) is installed on the barrel assembly. Slide the barrel and bolt channel assemblies together. Reinstall recoil spring on posts.
2. Apply a small amount of lubricant to bolt channel (exterior and interior where it covers the barrel) and inner housing. Turn assembly over and install Safety Spring into hole in bolt channel. Hold the spring down so the curved end stays over the slot in the channel. Hold Barrel/Channel assembly firmly and slide assembly into housing.
3. Reinstall the eight (8) screws in the fore grip. NOTE: MAKE SURE SCREW HOLES IN HOUSING LINE UP WITH THE HOLES IN THE BARREL ASSEMBLY. IF THE SCREW HEADS ARE ALLOWED TO PINCH THE HOUSING THE BOLT WILL NOT MOVE FREELY.
4. Reinstall bolt handle. Cycle bolt and check that it is moving freely.

REASSEMBLY INSTRUCTIONS-CCU'S WITH THE QUAD-RAIL:

Follow steps 1-4 under BASE MODEL.

Reinstall screw in the long rail to barrel bracket.

Reinstall side rails and lower housing clamp.

Reinstall lower rail.

REASSEMBLY INSTRUCTIONS FOR MONO-RAIL, MINI-RAIL AND MINI-QUAD RAIL MODELS:

Follow steps 1-4 under base model.

Reinstall screw at end of long rail if needed.

Tighten all of the short rails.

IF YOU HAVE ANY QUESTIONS CONCERNING ANY OF THESE PROCEDURES PLEASE CALL TECH SUPPORT AT 866-433-2122.

WARRANTY:

For one year from the date of purchase to the ORIGINAL owner, if the Mech-Tech Systems CCU is operated and maintained according to the instructions in the owner's manual, Mech-Tech Systems will repair or replace, free of charge, any part found to be defective in material or workmanship. Customers are responsible for shipping charges for returning products to the factory. The factory will pay return shipping (U.S. customers only) for warranty repairs. Customers are responsible for all shipping/handling charges on non-warranty repairs. Contact Mech-Tech Systems for return details.

This warranty does not cover:

Items which become worn during normal use.

Repairs necessary because of abuse, negligence, accident, or failure to maintain or operate according to the owner's manual.

Unauthorized modifications to the CCU.

CCU that is used for commercial or rental purposes.

Mech-Tech Systems Inc.
3243 U.S. Highway 93 South
Kalispell, MT. 59901
www.mechtechsys.com
1-866-433-2122

Copyright Mech-Tech Systems Inc. 2014

All rights reserved